

## ASPECTS CONSIDERED IN NEW CFB BOILER DESIGN FOR NARVA POWER PLANTS

P. KINNUNEN\*

*Foster Wheeler Energia OY*  
P.O. Box 5, Fin-00441, Helsinki, Finland

*In 1993, as a joint effort of Eesti Energia and Foster Wheeler a pilot test program was established to determine key parameters for combustion of Estonian oil shale in fluidized-bed boilers. It was concluded that combustion of Estonian oil shale in a circulating fluidized-bed boiler can be successful if the following key points have been understood and taken into account in boiler design: attrition of the fuel and ash; fouling of convection heat surfaces; chlorine corrosion at high temperatures. This paper tells how the key problems above were solved and implemented in the new fluid-bed combustion boiler design for Narva power plants.*

### Combustion Tests with Estonian Oil Shale in 1994

The development of the fluid-bed combustion technology for oil shale at *Foster Wheeler (FW)* started in 1982. The understanding of the behavior of this difficult fuel in the fluid-bed combustion process increased considerably at *FW* during the demonstration project in Israel in 1987–1993.

*Eesti Energia (Estonian Energy Ltd)* and *FW* agreed on a joint combustion test program to develop fluidized-bed combustion technology for Estonian oil shale. The agreement was signed on the 14th of April 1993. As a result of this test program, *FW* provided a technical and commercial boiler plant proposal for Estonian oil shale. *Eesti Energia* defined the construction site. The program was executed with strong support and presence of Tallinn Technical University experts in oil shale combustion.

The following experience of the partners was utilized:

- *FW*'s existing commercial fluid-bed technology considering special features of Estonian oil shale, as well as their experience in combustion of Israeli oil shale.
- Experience of *Eesti Energia* and Tallinn Technical University obtained from oil shale combustion at Narva power plants.

---

\* e-mail: [pertti\\_kinnunen@fwfin.fwe.com](mailto:pertti_kinnunen@fwfin.fwe.com)

The 0.8-MW circulating fluidized-bed pilot plant was modified for Estonian oil shale combustion in *FW*'s R&D laboratory at Karhula. The following modes of operation were performed during the combustion tests:

- Circulating fluidized-bed (CFB) mode
- Fast fluidized-bed without solids' circulation ("turbulent" mode)
- Conventional fluidized-bed mode

The tests were focused on the influence of the following factors on combustion temperature and operational modes:

- Combustion stability and efficiency
- Gaseous emissions (CO, SO<sub>2</sub>, NO<sub>x</sub>, N<sub>2</sub>O, C<sub>x</sub>H<sub>y</sub>)
- Particulates' emissions (heavy metals in ash, as well as their solubility)
- Decarbonation rate of limestone present in oil shale
- Deposit formation and corrosion
- Ash utilization (analysis and mineralogy)

The Estonian partners shared their information on formation of severe hard deposits and chlorine corrosion in pulverized-fired boilers. Familiarity with the problems was gained during the visit of the boiler No. 23 at Baltic Power Plant, in January 1994 (Fig. 1).



Fig. 1. Hard deposits on superheater II, boiler No. 23, Baltic Power Plant

#### Tests with Estonian Oil Shale in 1994

	CFB mode	Turbulent mode
OM content of the shale, %	29–32	29–32
NO <sub>x</sub> , ppm	<129	<71
SO <sub>x</sub> , ppm	0	26–86
CO, ppm	66–183	61–158
Combustion efficiency, %	>97	>97
Decarbonation rate, %	>70	>70

The tests were carried out in two phases in autumn 1994 at Karhula. The conventional fluidized-bed combustion runs resulted in unstable operation of the pilot unit, and further testing in this mode was stopped. The test runs

were continued with CFB and turbulent modes, and a summary of the tests is presented in the Table.

At evaluation, circulating fluid-bed design was considered the best one basing on the following advantages:

- Stable operation at all loads
- Hard deposit formation is minimized due to complete sulfur binding in the furnace
- Soft deposits can be handled through proper design parameters of the furnace: correct back-pass design, and rapping- and sonic-type sootblowers.
- Application of CFB together with “in-bed” superheater provided an advantage over chlorine corrosion (Intrex™ heat exchanger)

A part of load runs in CFB mode showed clearly that fluidization velocity has a large impact on formation of soft deposits in the back-pass. High velocity leads to a high attrition rate, and consequently to an intensive need for cleaning. With lower fluidization velocities, attrition was reduced significantly. The operation of the cyclone and loop-seal remained stable.

During the years 1996–2000 the commercial application development was performed. Optimization of the CFB design details was made. Different plant sizes were studied at several locations leading to the final design of the 100-MWe single boiler units for Narva power plants (Fig. 2).

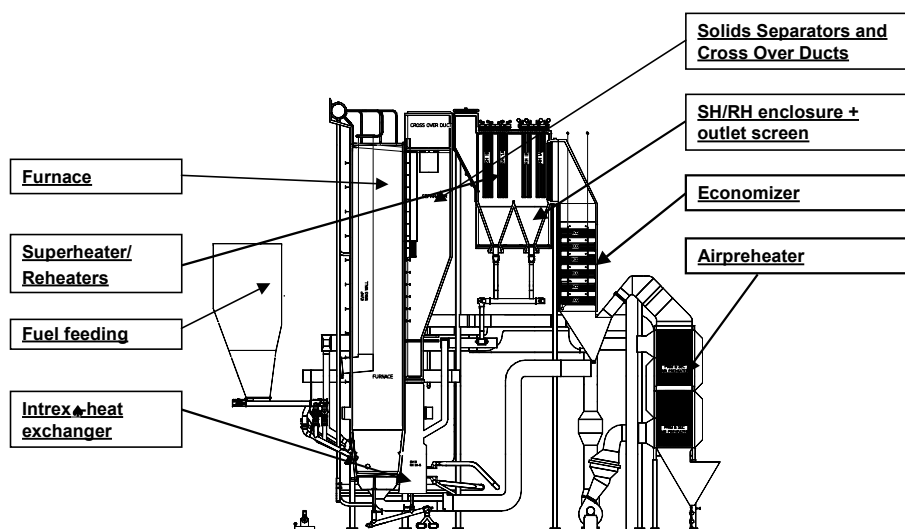

Fig. 2. Boiler concept for Estonian oil shale

## Conclusions

Combustion of Estonian oil shale in circulating fluidized bed can be done successfully if the following key problems have been understood and considered in boiler design:

1. **Attrition (friability of the fuel and ash).** Correct furnace design parameters have to be selected in order to avoid attrition and formation of soft deposits on the convection heat surfaces.
2. **Fouling of convection heat surfaces.** To avoid fouling of convection heat surfaces:
  - Sulfur must be completely bound in the furnace to minimize its reactions on the convection heat surfaces and formation of hard deposits.
  - Even fuel distribution in the furnace is arranged by numerous feeding points.
  - Spring hammer rappers and sonic sootblowers are selected for back-pass cleaning.
  - Space for convection heat surfaces must be reserved for later surface addition.
3. **Chlorine corrosion at high temperature.**
  - Location and arrangements of superheaters *versus* gas temperature must be selected optimally to maintain low metal temperatures
  - Heat surface materials are to be selected considering the capabilities of the local maintenance crew.
  - Strategic heat surfaces must be designed for easy replacement.